



SHADOW 108CT / EN

MULTIPURPOSE 8" COAX

IP55



EN 54-24:2008

CERTIFICATE OF CONSTANCY OF PERFORMANCE
n. 0068/CPR/011-2019

ATTESTATION OF CONFORMITY
n. CPR/181446_1-1-2019
EN 60529:1991-10



KEY FEATURES

- 2-way multipurpose 8" coax
- Sturdy molded polypropylene curved enclosure
- 8" coaxial woofer with 2" coil
- 1" HF driver with 1.4" coil
- Line transformer
- 4 wires cable to select the power tapping
- IP55 weather resistant
- Standard black color
- Completely manufactured in Italy

APPLICATIONS

- Convention centers
- Athletic fields
- Stadiums
- Theme parks
- Swimming pools
- Cruise ships
- Malls
- Ballrooms
- Outdoor background music

PRODUCT DESCRIPTION

The FBT SHADOW 108CT/EN is a weatherproof coaxial two way loudspeaker system offering substantial power and efficiency for a variety of professional indoor or outdoor applications. The low frequency transducer is a 8" woofer with a 2" voice coil. The high frequency section is a 1" driver with 1.4" voice coil on conical 90° horn. The FBT SHADOW 108CT/EN features a standard 100V line transformer. The cabinet is a single piece rotational moulded in polypropylene, fully UV protected. The FBT SHADOW 108CT/EN is internal equipped with ceramic terminal block and thermal fuses ensuring the continued operation of loudspeakers in the event of a fire; in addition all connections use flame-retardant cabling which adheres to the EN50200 standard (with IP68 airtight cable glands). The cabinet is equipped with a stainless steel U-bracket. The grille is in custom perforated stainless steel with 3 layers of protection. The FBT SHADOW 108CT/EN meets the requirements of IP55 code (International Protection Rating).

TECHNICAL SPECIFICATIONS

Configuration	2 Ways
Recommended amplifier	300 W RMS
Rated noise power 100 hrs (voltage)	150 W (33,5V)
System short term power IEC268-5	600 W
Nominal impedance 100V line	85 Ohm 120W / 166 Ohm 60W
Frequency response (@-6dB)	94Hz - 20kHz
Sensitivity (@1W / 1m)	94dB
Max. SPL (1m / 4m)	115dB / 103dB
Crossover frequency	1,8kHz
Recommended HP Filter	70Hz - 24dB oct.
Dispersion Horizontal (-6dB)	500Hz: 160° 1kHz: 100° 2kHz: 90° 4kHz: 80°
Dispersion Vertical (-6dB)	500Hz: 160° 1kHz: 100° 2kHz: 90° 4kHz: 80°
Operating / Storage temperature	-25°C to +55°C / -40°C to +70°C
Relative umidity	<95%

PHYSICAL SPECIFICATIONS

Low frequency woofer	1 x 8" / 2" coil
High frequency driver	1 x 1" / 1,4" coil
Input connectors	4 wire cable
Net dimensions (WxHxD)	11,22 x 11,22 x 9,84 inch
Shipping dimensions (WxHxD)	14,37 x 14,37 x 12,99 inch
Net weight	22,04 lbs
Shipping weight	27,55 lbs
Enclosure material	Polypropylene



SHADOW 108CT / EN

Horizontal polar diagram

— 250 — 500 — 1000 — 2000

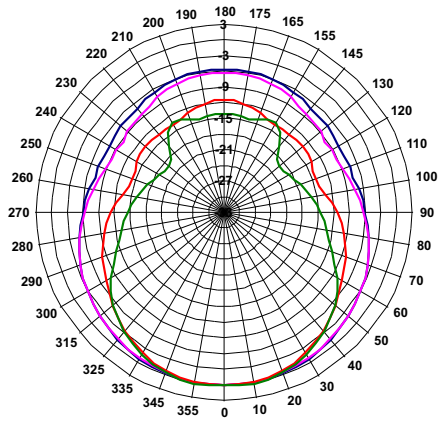

Horizontal polar diagram

— 4000 — 8000 — 12500 — 16000

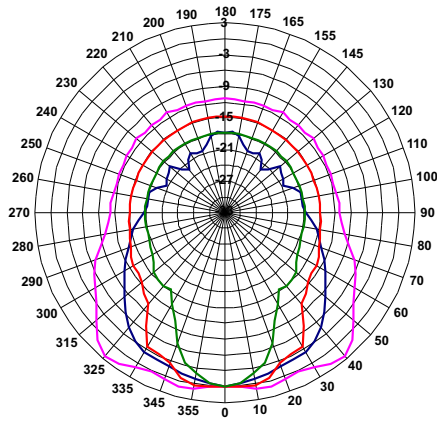

Vertical polar diagram

— 250 — 500 — 800 — 1000

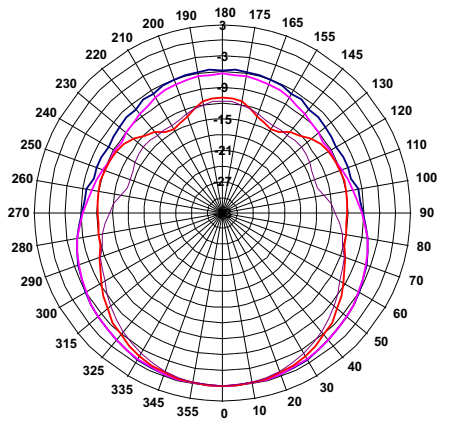

Vertical polar diagram

— 1400 — 2000 — 2500 — 3150

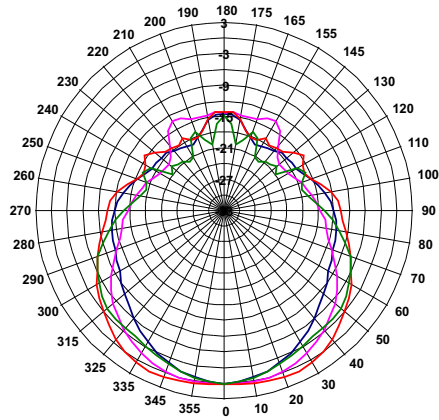

Vertical polar diagram

— 4000 — 5000 — 6300 — 8000

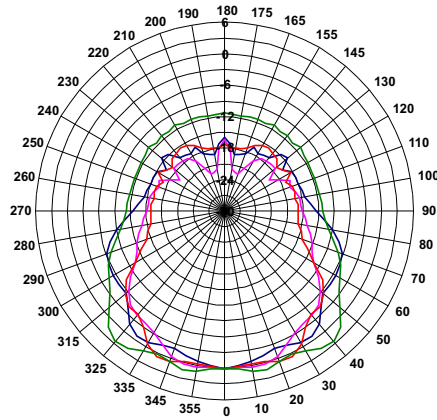

Vertical polar diagram

— 9000 — 10000 — 12500 — 14000

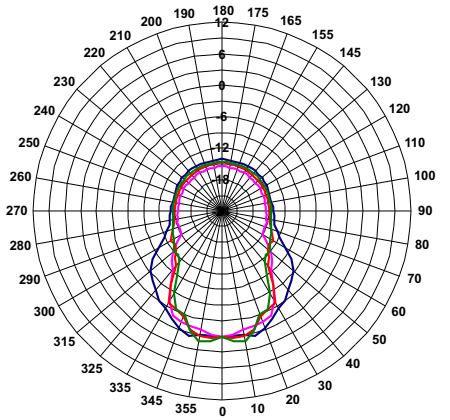

Frequency Response

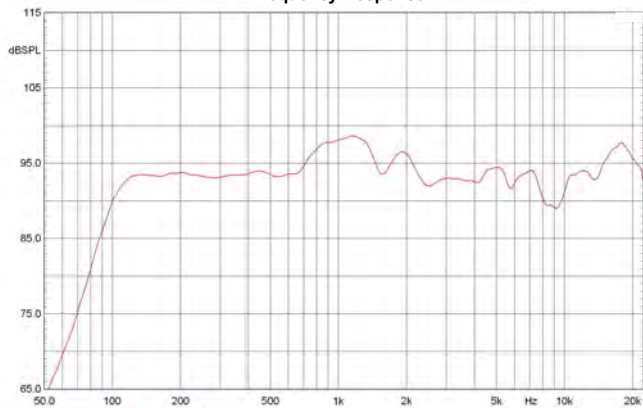

Loudspeaker physical references

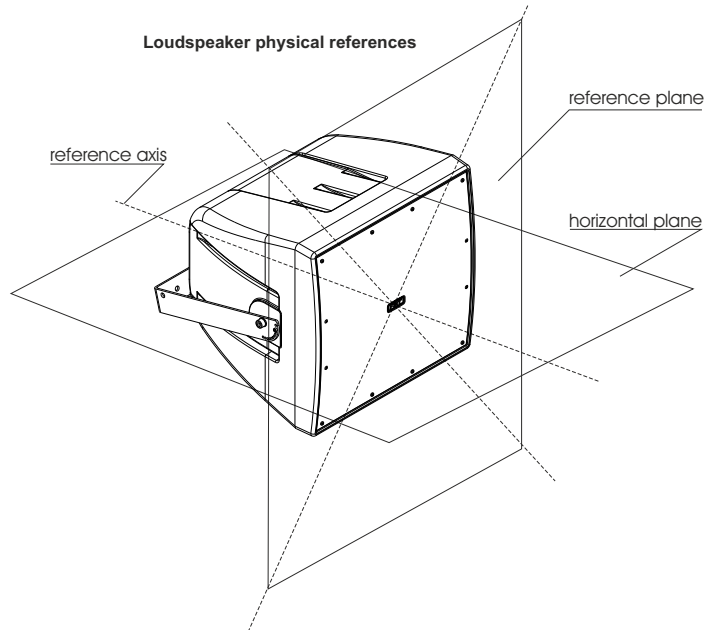



SHADOW 108CT / EN

DIMENSIONAL DRAWINGS

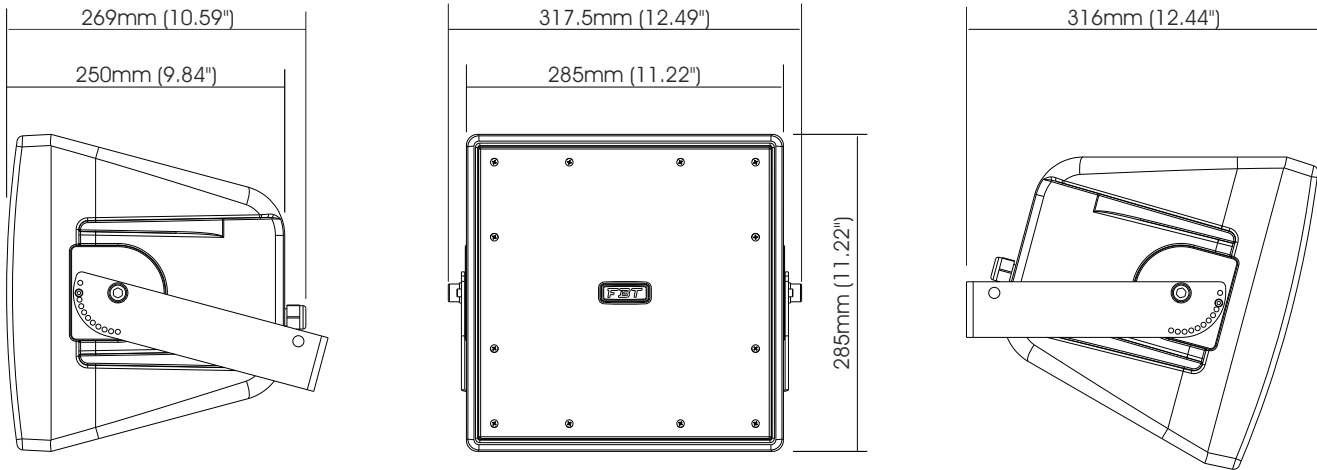

TECHNICAL SPECIFICATIONS LABEL

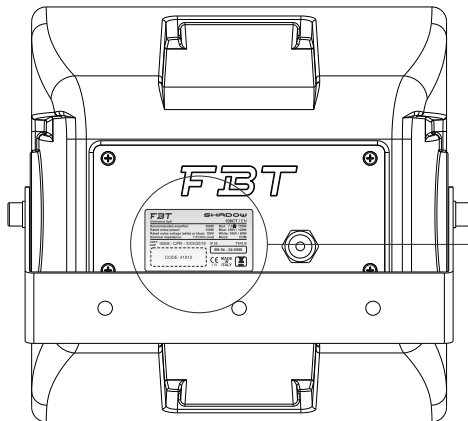

FBT Elettronica SpA	SHADOW 108CT / EN
Recommended amplifier:	300W Red: 7,5Ω / 150W
Rated noise power:	150W Blue: 100V / 120W
Rated noise voltage (white or blue):	100V White: 100V / 60W
Nominal impedance:	7,5 Ohm (red) Black: COM
CERT. DOP: 0068 - CPR - 011/2019	EN 54 - 24:2008
CODE: 41910	IP 55 TYPE B
	CE MADE IN ITALY

INCLUDED ACCESSORY

